

# METROLAB

Magnetic precision has a name

## MAGVECTOR™ MV2 3-AXIS MAGNETIC SENSOR

THE WORLD'S MOST FLEXIBLE HALL SENSOR

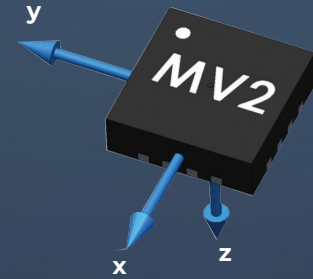

**Small package**  
QFN 3x3x0.9mm<sup>3</sup>, 16  
leads + thermal pad,  
MRI compatible



**Flexible Power**  
3.3 or 5 V



**Flexible Outputs**  
> B<sub>x</sub>, B<sub>y</sub>, B<sub>z</sub>, T (on-chip  
temperature)  
> Analog or digital (SPI)  
> Selectable 3-axis or  
single-axis



**Selectable field  
ranges**  
0.1, 0.3, 1, 3, 10 or 30T



**Selectable  
resolution**  
14, 15, 16 or 16+  
bits



**Selectable  
sample rate**  
375, 750, 1500 or 3000



**Microscopic field-  
sensitive volume**  
200x200x5μm<sup>3</sup>



**Low noise**  
RMS < 2.0  
LSB (16+ bit  
resolution)



**Integrated spin-  
ning current**  
Suppression of noise,  
offset, Planar Hall Ef-  
fect



**Parallel Operation**  
Single SPI bus, multiple  
Chip Select, synchro-  
nized ADC



**Wide Operating  
temperature range**  
-40 to +125°C, tested in  
liquid nitrogen



### ABOUT METROLAB

We are the **global market leader** for precision magnetometers.

Established in Switzerland in **1985**, we have won the trust of all the large physics laboratories and all leading players in Magnetic Resonance Imaging, **across the world.**

With Metrolab, you measure magnetic fields with **Swiss precision and quality.**

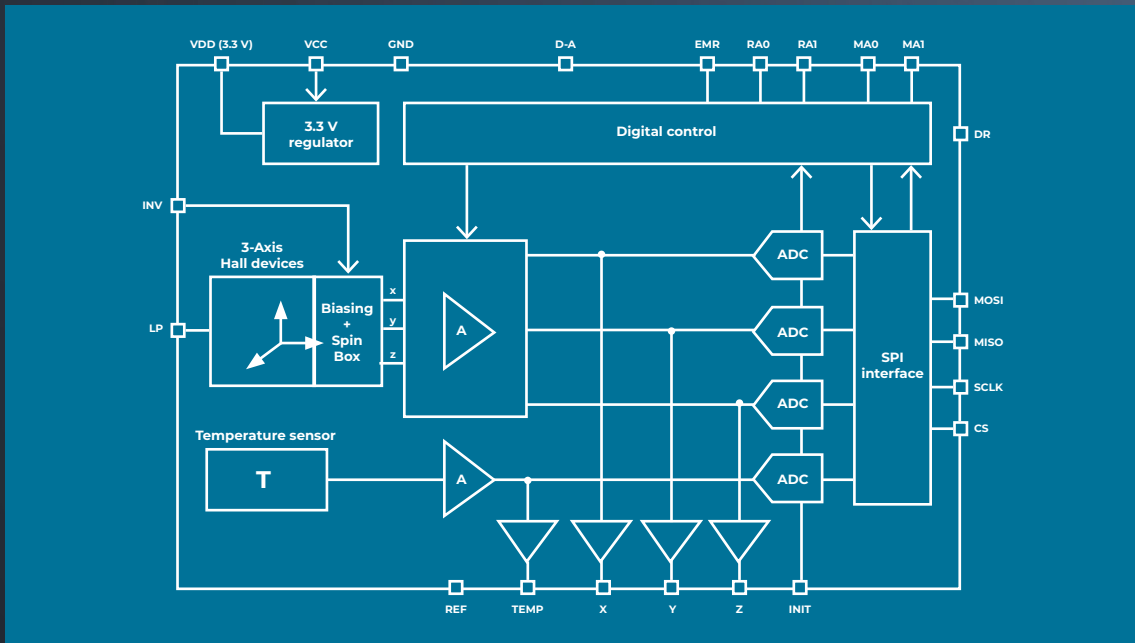

The MagVector™ MV2 allows you to integrate a sophisticated magnetometer into your electronic system. A typical application is a sensor array for magnetic field monitoring. The MV2 was developed by MPS Tech Switzerland Sàrl, in cooperation with Metrolab. Metrolab uses the same sensor in several of its products, and is now making this technology available to electronic systems designers.

Note, that an electronic component such as the MagVector™ MV2 provides none of the amenities of, for example, Metrolab's 3-axis Hall magnetometers: the user must supply the micro-controller, control firmware, host interface, user interface, and, last but not least, calibration.

### SMALL BUT POWERFUL

Measuring only 3x3x0.9mm<sup>3</sup>, the MagVector™ MV2 is a powerful magnetometer on a chip: three orthogonal Hall sensors measure ( $B_x$ ,  $B_y$ ,  $B_z$ ); the «spinning current» technique minimizes noise, offset and the Planar Hall Effect; a built-in temperature sensor permits temperature compensation, a programmable-gain amplifier provides measurement ranges from 0.1 to 30 T; and built-in ADCs and SPI (Serial Peripheral Interface) provide a digital interface in addition to an analog one.

### HIGH PERFORMANCE

The MV2 features a noise density of 300 nT/√Hz and an analog measurement bandwidth of 50 kHz. In digital mode, measurement rate can be traded off against ACD resolution, ranging from 0.375 to 3 kHz, and from 14 to 16+ bits, respectively. It supports a supply voltage of 3.3 or 5 V. The compact 3x3mm<sup>2</sup> QFN package is completely nonmagnetic, compatible with MRI environments. Please see the Data Sheet for details.

### ANALOG AND DIGITAL

A signal pin selects between the analog or digital interface. In analog mode, configuration options such as the measurement range are selected using control signals, whereas in digital mode all configuration parameters are transferred via SPI and stored in internal registers. Additional control signals and register bits provide fine control over the measurement process, for example the timing of the analog/digital conversion. In digital mode, multiple MV2s can be connected to a single SPI bus.

For detailed specifications, please see [www.metrolab.com](http://www.metrolab.com)

### METROLAB TECHNOLOGY SA

110, ch. du Pont-du-Centenaire, 1228 Geneva, Switzerland

+41 22 884 33 11

contacts@metrolab.com

www.metrolab.com