

MagVector™ MV2 3-Axis Magnetic Sensor

Datasheet

Version 2.2

(Revision 1.0)

March 2017

REVISION HISTORY

v. 0.1	December 2013	- Unpublished -
v. 0.2	January 2014	- Unpublished - Specific notes to MagVector MV2 release 1 added Thermometer data in table 4 Options renamed (BSM, DRP) Various corrections
v. 0.3	January 2015	- Unpublished - Range extension option
v. 1.0 r. 1.0	December 2015	First release
v. 1.1 r. 1.0	February 2016	Update and complete general specifications Add a section on mounting precautions Correct minimum ADC resolution: 14 bits, not 13 Miscellaneous corrections
v. 2.0 r. 1.0	July 2016	Add documentation of Evaluation Kit Require control signal levels to match VCC Note about using INV in Digital mode Miscellaneous clean-ups
v. 2.1 r. 1.0	September 2016	Add 0xC4 “Get version” command for Eval Kit firmware
v. 2.2 r. 1.0	March 2017	3-6: Note that the on-chip regulator tends to drift 4-1, 5-1: Replace incorrect sensitivity specs with design targets; measured values are TBD 4-4: Correct typos in Figure 5 5-3, 5-5: Clarify operation of DR and INIT 5-14: Add explanatory footnote for Refresh Rate 5-16: Describe noise characteristics of single-axis modes 6-4-2: Clarify the <COM port> parameter

MagVector™ MV2 3-axis magnetic sensor

1-Overview

1-1 FEATURES

Measures total field: 3-axis

Selectable measurement ranges:
from 100 mT to 30 T

Low noise: 300 nT/√Hz

Supply voltage: 3.3 V or 5 V

Analog and digital interfaces

Selectable measurement rate: up to 3 kHz

Selectable resolution: 14 to 16 bits

Non-magnetic package

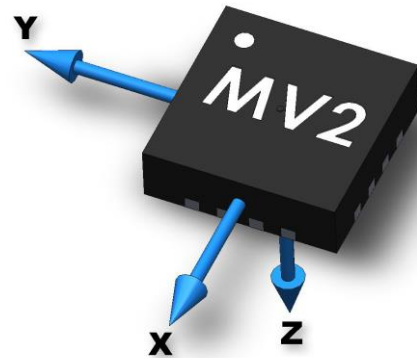

1-2 SAMPLE APPLICATIONS

High performance embedded applications

Custom multi-probe field mappers

Magnetic flux leakage measurement

1-3 GENERAL DESCRIPTION

The MagVector™ MV2, designed and manufactured by MPS Tech Switzerland (formerly Sensima Technology) in Gland, Switzerland, is a robust 3-axis magnetic Hall effect sensor. It features an analog as well as digital interface, selectable by the user. The analog mode delivers voltages proportional to the magnetic field, and the measurement range is configurable via simple wiring. In the digital mode, the MagVector MV2 communicates through a Serial Peripheral Interface (SPI) for configuration and data delivery. The non-magnetic QFN package is compatible with MRI environments.

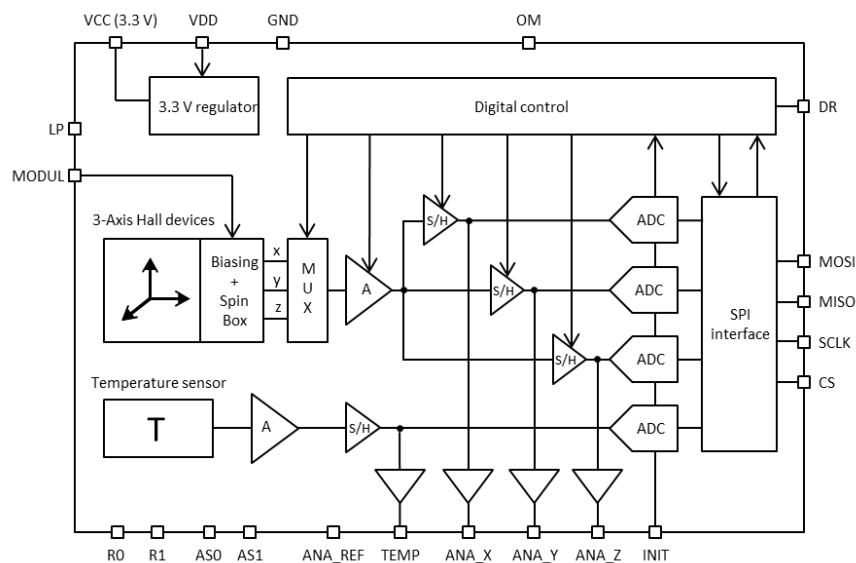

Figure 1. Block diagram

MagVector™ MV2 3-axis magnetic sensor

2-Document contents

2-1 TABLE OF CONTENTS

1- Overview	iii
1-1 Features.....	iii
1-2 Sample Applications.....	iii
1-3 General Description	iii
2- Document contents	iv
2-1 Table of contents.....	iv
2-2 List of Figures	v
2-3 List of Tables.....	vi
3- General	1
3-1 Package dimensions and marking.....	1
3-2 Mounting Precautions	2
3-3 Absolute Maximum Ratings.....	2
3-4 Operating Conditions	3
3-5 Pinout.....	4
3-6 Power Supply.....	5
3-7 Operating Modes.....	6
3-8 Sensing Device	6
3-9 Signal Conditioning	7
3-10 Measurement Axis selection	7
4- Analog Mode Operation	8
4-1 Specifications.....	8
4-2 Signal Conditioning – Analog Mode	9
4-3 Output stage	9
4-4 Application Circuit	10
4-5 Option settings in analog mode	10
4-6 RA – Range	11
4-7 MA – Measurement Axis	11
4-8 LP – Low Power	11
4-9 INV – Invert	12
4-10 EMR – Extended Measurement Range	12
5- Digital Mode Operation	13
5-1 Specifications.....	13
5-2 Signal Conditioning – Digital Mode.....	14
5-3 A/D conversion.....	14

5-4	Output stage	15
5-5	Application Circuit	15
5-6	Multiple devices	16
5-7	Serial communication	16
5-8	Communication Protocol	17
5-9	Data format – Data In	18
5-10	Data Format – Data Out	19
5-11	Registers	19
5-12	OS – Output Selection	21
5-13	RA – Range	21
5-14	RE – Resolution	22
5-15	MA – Measurement Axis	22
5-16	SP – Status Position	23
5-17	PO – Permanent Output	24
5-18	LP – Low Power	24
5-19	INV – Invert	24
5-20	HC – High Clock	24
5-21	EMR – Extended Measurement Range	24
5-22	LMR – Large Measurement Range	25
5-23	TC – Temperature Compensation	25
6-	Evaluation Kit	26
6-1	Test Board	26
6-2	Arduino Board	28
6-3	Arduino Firmware	30
	6-3-1 <i>Functional overview</i>	30
	6-3-2 <i>Command definitions</i>	30
	6-3-3 <i>Return status definitions</i>	32
	6-3-4 <i>Rebuilding the firmware</i>	32
6-4	Host Software	32
	6-4-1 <i>Functional overview</i>	33
	6-4-2 <i>Installation and execution</i>	33
	6-4-3 <i>Setup file format</i>	34
	6-4-4 <i>Recompilation</i>	34
	6-4-5 <i>Development environment</i>	35
	6-4-6 <i>Installing the libxml2 library</i>	36

2-2 LIST OF FIGURES

Figure 1.	Block diagram	iii
Figure 2.	Connections for 5 V supply (left) and 3.3 V supply (right)	5
Figure 3.	Conceptual diagrams of horizontal (left) and vertical (right) Hall sensors	6
Figure 4.	Block diagram of the signal conditioning – analog mode	9
Figure 5.	Circuits for sensor control and reading – analog mode	10
Figure 6.	Block diagram of the signal conditioning – digital mode	14
Figure 7.	Circuit for sensor control and reading – digital mode	16
Figure 8.	Parallel connection of MagVector MV2s	16

Figure 9. Timing diagram of one word	17
Figure 10. Sequence of data for communicating with the MagVector MV2	17
Figure 11. Timing diagram of the register read back	18
Figure 12. Format of Data In	18
Figure 13. Format of Data Out.....	19
Figure 14. Output of one particular axis as a function of the field amplitude when the resolution is 16 bits, unsigned value representation.....	19
Figure 15. Timing of the data out when the resolution set to 14 bits.	22
Figure 16. MagVector MV2 Evaluation Kit test board.	26
Figure 17. Schematics of MagVector MV2 Evaluation Kit test board	27
Figure 18. Arduino/Genuino UNO connected to MagVector MV2 test board.	29

2-3 LIST OF TABLES

Table 1. Absolute maximum ratings	2
Table 2. Operating conditions.....	3
Table 3. Pinout – analog mode operation	4
Table 4. Pinout – digital mode operation	5
Table 5. Operating modes.....	6
Table 6. Performance specifications in analog mode	8
Table 7. Selectable options – analog mode.....	10
Table 8. Range selection – analog mode	11
Table 9. Measurement axis selection – analog mode.....	11
Table 10. Performance specifications in digital mode.....	13
Table 11. Serial Peripheral Interface specification	14
Table 12. Format of Data In	18
Table 13. Contents of Register 00.....	20
Table 14. Contents of Register 01.....	20
Table 15. Contents of Register 10.....	20
Table 16. Output Selection.....	21
Table 17. RA – Range selection – digital mode.....	21
Table 18. RE – Resolution Selection	22
Table 19. MA – Measurement axis selection – digital mode	23
Table 20. Status Position bit.....	23
Table 21. Signal routing of MagVector MV2 Evaluation Kit test board.....	28
Table 22. Connections from MagVector MV2 Evaluation Kit test board to external digitizer.	28
Table 23. Command definitions.....	31
Table 24. Return status definitions	32

MagVector™ MV2 3-axis magnetic sensor

3-General

3-1 PACKAGE DIMENSIONS AND MARKING

Package: 16L QFN 3x3x0.9mm, 0.50mm pitch with exposed pad of 1.70x1.70mm

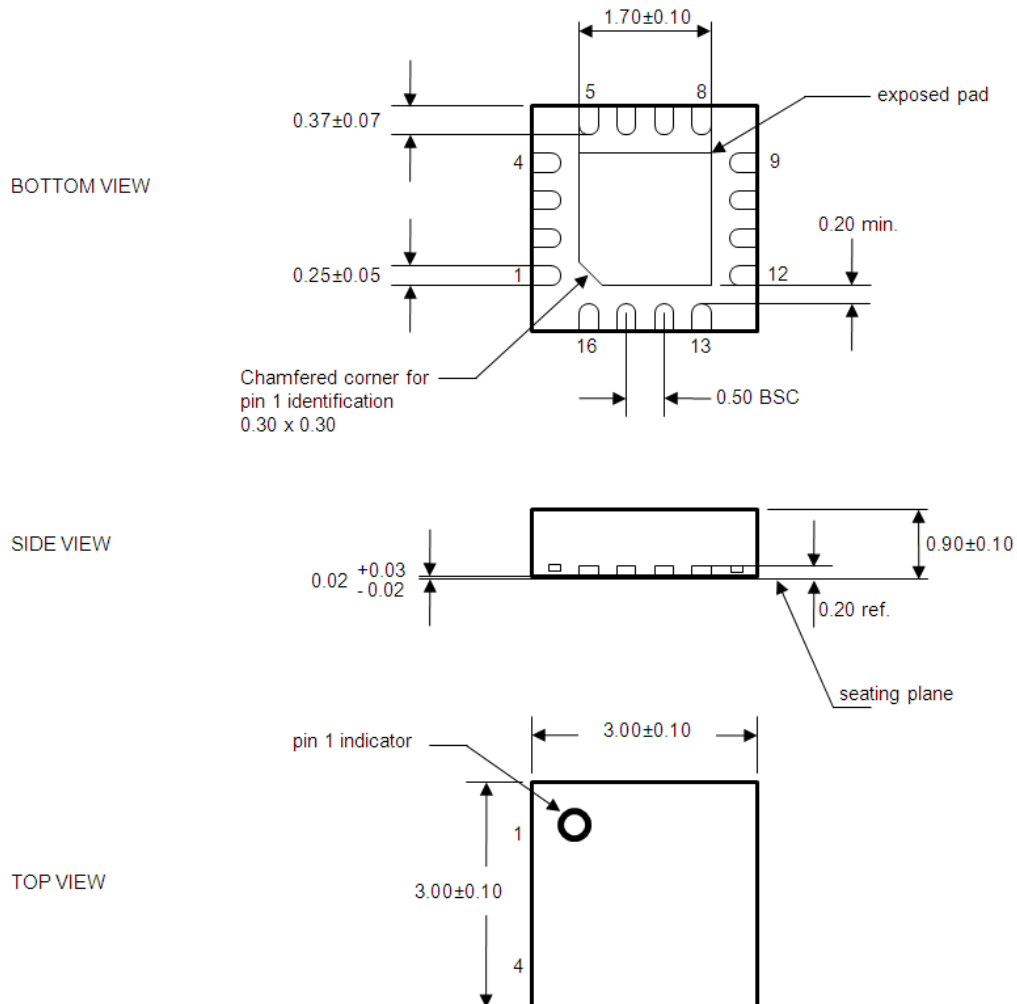

NOTES:

All dimensions are in mm.

Package dimensions do not include mold flash, protrusions, burrs or metal smearing.

Co-planarity applies to the exposed terminals. Maximum co-planarity shall be 0.08.

Compliant with JEDEC-220.

Marking: 3 lines, e.g. "03/MV2/5AC". The first line is the version number, the second is the product identifier, and the third is an internal identification code.

3-2 MOUNTING PRECAUTIONS

When mounting the MagVector MV2 on the printed circuit board (PCB), it is important to avoid stress. Stress induces piezoelectric voltages that interfere with the measurement of the Hall voltages; in particular, they vary with temperature and can cause offset drifts with very long time constants.

Specific recommendations include:

- PCBs made of FR-4 are recommended over, for example, ceramic PCBs, since the coefficient of thermal expansion of the substrate better matches that of the package.
- After soldering, the package should not be mechanically constrained in any way.

3-3 ABSOLUTE MAXIMUM RATINGS

Table 1. Absolute maximum ratings

Parameters	Min	Max	Unit
DC voltage at VCC	-0.5	7	V
DC voltage at VDD	-0.5	4	V
Input current on any pin (1)	-100	100	mA
Electrostatic discharge (2)		±2	kV
Package thermal resistance:			
– Junction to ambient (Theta JA)		50	°C/W
– Junction to case (Theta JC)		12	°C/W
Storage temperature	-40	150	°C

Notes:

These values denote absolute maximum ratings. These ratings are stress ratings only. Functional operation of the device at these conditions is not implied. Exposure to absolute maximum rating conditions for extended periods may affect device reliability.

(1) Norm: JEDEC78

(2) Norm: MIL 883 E method 3015

3-4 OPERATING CONDITIONS

Table 2. Operating conditions

Parameter	Symbol	Min	Typ	Max	Unit
DC supply voltage	VCC	4.5	5	5.5	V
DC supply voltage	VDD	3.28	3.3	3.32	V
DC supply current	I _{sup}	17	18.5	20	mA
Digital input signals:					
– “Low” input voltage	V _{il}			30% of VCC	V
– “High” input voltage	V _{ih}	70% of VCC			V
– Input current	I _i	±30		±100	µA
Digital output signals:					
– “Low” output voltage (1)	V _{ol}			0.4	V
– “High” output voltage (2)	V _{oh}	4			V
Operating temperature	T _{op}	-40		+125	°C

Notes:

The maximum drive capability of the analog outputs is 100 kΩ / 500 pF.

The digital input levels must match the supply used: 5 V when supplied with 5 V and 3.3 V when supplied with 3.3 V.

The digital output level matches the supply used: 5 V when supplied with 5 V and 3.3 V when supplied with 3.3 V.

Measurement conditions: VCC = 5 V; I_o = +1 mA.

Measurement conditions: VCC = 5 V; I_o = -1 mA.

3-5 PINOUT

Top view:

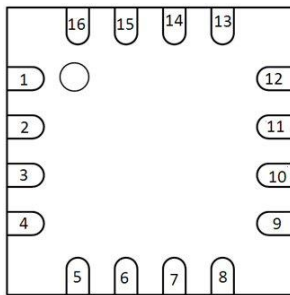

The functions of the pins differ according to the mode of operation, analog or digital – see Table 3 and Table 4. Unused pins can be left unconnected; the internal pull-down resistor is ~100 kΩ.

Table 3. Pinout – analog mode operation

Pin	Name	Type	Direction	Description	Pad input option
1	RA0	Digital	In	Field range 0	Pull-down
2	RA1	Digital	In	Field range 1	Pull-down
3	MA0	Digital	In	Meas. Axis 0	Pull-down
4	MA1	Digital	In	Meas. Axis 1	Pull-down
5	Z	Analog	Out	Z-axis output	
6	TEMP	Analog	Out	Temperature output	
7	REF	Analog	Out	Volt. reference (VCC/2)	
8	VDD	Supply	Power	Internal core supply voltage (3.3 V)	
9	D-A	Digital	In	Digital - Analog mode	1
10	LP	Digital	In	Low power mode	Pull-down
11	INV	Digital	In	Output inversion	Pull-down
12	EMR	Digital	In	Extended Measurement Range	Pull-down
13	GND	Supply	Power	Ground	
14	VCC	Supply	Power	Main supply voltage (5 V)	
15	Y	Analog	Out	Y-axis output	
16	X	Analog	Out	X-axis output	

Table 4. Pinout – digital mode operation

Pin	Name	Type	Direction	Description	Pad input option
1	MISO	Digital	Out	Serial MISO	Pull-down
2	SCLK	Digital	In	Serial CLK	Pull-down
3	CS	Digital	In	Serial CS	Pull-down
4	MOSI	Digital	In	Serial MOSI	Pull-down
8	VDD	Supply	Power	Internal core supply voltage (3.3 V)	
9	D-A	Digital	In	Digital - Analog mode	0 or floating
10	INIT	Digital	In	ADC initialization	Pull-down
11	INV	Digital	In	Analog mode output inversion	0 or floating
12	DR	Digital	Out	Data ready	Pull-down
13	GND	Supply	Power	Ground	
14	VCC	Supply	Power	Main supply voltage (5 V)	

Unused pins may be left unconnected. Note, however, that the INV control line, normally used only for Analog mode, also affects Digital mode operation; consequently, if connected in Digital mode, it should be tied to LOGIC 0.

3-6 POWER SUPPLY

The MagVector MV2 is designed to be supplied with 5 V. An on-chip voltage regulator reduces and stabilizes the 5 V down to 3.3 V, which is the chip core supply voltage. However, it is also possible to supply the chip with 3.3 V. In that case, since there is no regulation, the supply needs to be stable within 0.5 % to reach the specified resolution.

The digital output level matches the supply used: 5 V when supplied with 5 V and 3.3 V when supplied with 3.3 V.

When using a 5 V supply, the internal core supply voltage can be monitored on the VDD pad.

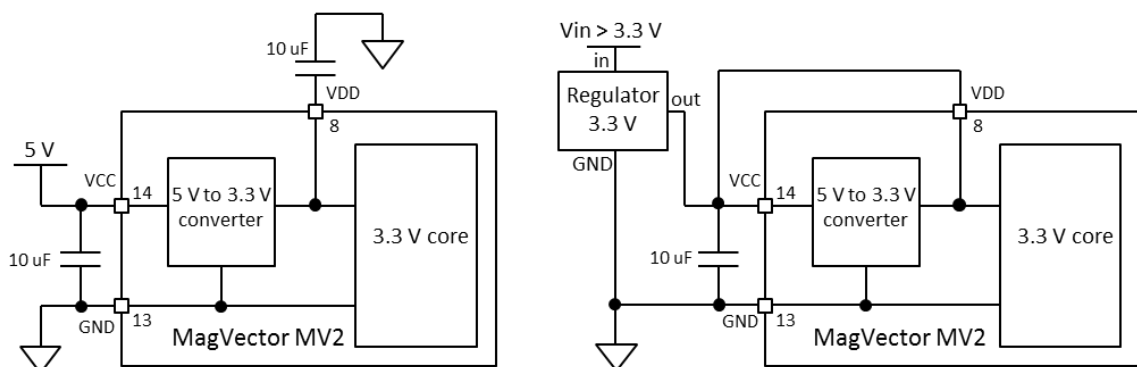

Figure 2. Connections for 5 V supply (left) and 3.3 V supply (right)

Notes:

For best performance, use the 3.3 V configuration, with a high-precision external voltage regulator. The on-chip voltage regulator is sensitive to temperature drift.

In the 3.3 V configuration, VCC must be shorted to VDD.

The 10 μF capacitor values are approximate recommendations. In the 3.3 V configuration, the choice of the value of the decoupling capacitor depends on the specifications of the external voltage regulator. It is recommended to place a 100 nF decoupling capacitor in parallel to each 10 μF capacitors.

3-7 OPERATING MODES

The MagVector MV2 can be operated in two modes: digital or analog, depending on the logic level of the D-A input pin. If the D-A pin is tied to LOGIC 0 or left floating, the MagVector MV2 is operating in digital mode (default). In order to switch the operating mode of the MagVector MV2 from digital to analog, the D-A pin has to be tied to LOGIC 1 (VCC).

Table 5. Operating modes

D-A	Mode	See:
0	DIGITAL	Page 13, Section 5-Digital Mode Operation
1	ANALOG	Page 8, Section 4-Analog Mode Operation

3-8 SENSING DEVICE

The three components of the magnetic field are detected by three orthogonal Hall devices: the component B_z normal to the die plane is detected by a conventional “horizontal” Hall sensor, whereas the two in-plane components B_x and B_y are detected by “vertical” Hall sensors (see Figure 3).

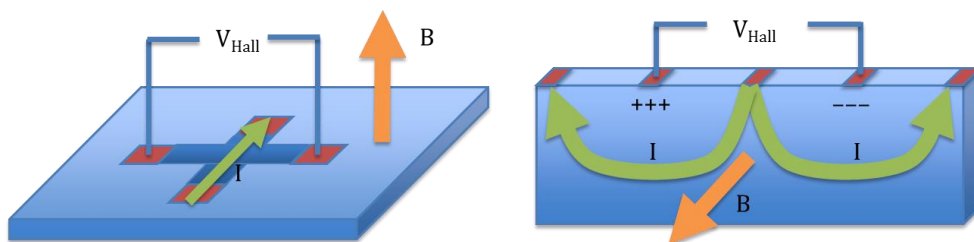

Figure 3. Conceptual diagrams of horizontal (left) and vertical (right) Hall sensors

The directions of the axes (B_x , B_y , B_z), relative to the QFN package, are shown in the diagram in Section 1-Overview. The axes are oriented as indicated by the arrows in digital mode, in the opposite direction in analog mode (see Section 3-7).

The input and output leads of the Hall devices are sequentially permuted. This “spinning current” technique has several significant benefits: it minimizes the offset and, more importantly, the offset drift; it minimizes the Planar Hall Effect; and it minimizes 1/f noise.

The sensing volume has the shape of a thin square slab, 200x200 μm in the die plane and about 5 μm high. The Hall sensors are distributed such that the measured Hall voltage of all three axes closely approximates the flux density averaged throughout the slab. The sensing volume is located, with a precision of 50 μm , in the center of the QFN package, both horizontally and vertically.

3-9 SIGNAL CONDITIONING

By default, the 3 measurement signals are sequentially multiplexed, amplified and de-multiplexed (see Figure 4 for analog mode and Figure 6 for Digital Mode). This means that a single amplifier is used for all 3 axes. By controlling the gain, the user sets the magnetic field range. A separate, fixed-gain amplifier amplifies the temperature sensor output.

By default, the following ranges can be selected: 100 mT, 300 mT, 1 T and 3 T. The amplifier saturates when the magnetic field strength exceeds the range value by approximately 20%; for instance, if the range is 100 mT, the output saturates at around 120 mT.

Additional option bits allow the range to be extended by 30% or by a factor 10x – see Section 12 for analog mode and Sections 5-21 and 5-22 for digital mode,

3-10 MEASUREMENT AXIS SELECTION

By default, the 3 magnetic axes are multiplexed continuously at a rate well above the output frequency.

It is possible to prevent the continuous multiplexing and amplify just the x-, y- or z-axis. Single-axis mode is useful when the user wants to optimize the signal-to-noise ratio of one particular axis.

This mode is also recommended when a large magnetic field is applied in a direction other than the one being measured. In such conditions, without enabling the single-axis mode, the amplifier may saturate when amplifying the large Hall voltage. Since the amplifier recovery time is relatively long, the saturation can affect the value read for other axes.

Note that in single-axis mode, only one of the 3 magnetic field channels provides meaningful values. For instance, if the selected measurement axis is only x, the channels y and z are disabled, and therefore provide non-usable outputs.

MagVector™ MV2 3-axis magnetic sensor

4-Analog Mode Operation

4-1 SPECIFICATIONS

Table 6. Performance specifications in analog mode

Performance specifications in analog mode, VDD = 5 V, T = 25°C						
Parameter		Min	Typ	Max	Unit	Note
Sensitivity ¹	3 T range		0.69		V/T	
	1 T range		2.08			
	300 mT range		69.4			
	100 mT range		20.8			
Sensitivity drift	All ranges		±200	±400	ppm/°C	
Measurement bandwidth		50			kHz	
Repeatability				0.1	%	
Spectral noise density	X & Y axis		330		nT/√Hz	
	Z axis		225		nT/√Hz	
RMS noise	X & Y axis		8		μT	RMS (0 - 600 Hz)
	Z axis		5.5		μT	RMS (0 - 600 Hz)
Static offset			30	50	mV	With respect to VCC/2
Offset temperature drift				0.1	mV/°C	
Temperature output sensitivity			4.2		mV/°C	
Temperature output @ 27°C		1.25		1.35	V	

¹ Design targets; measured typical, minimum and maximum values are TBD.

4-2 SIGNAL CONDITIONING – ANALOG MODE

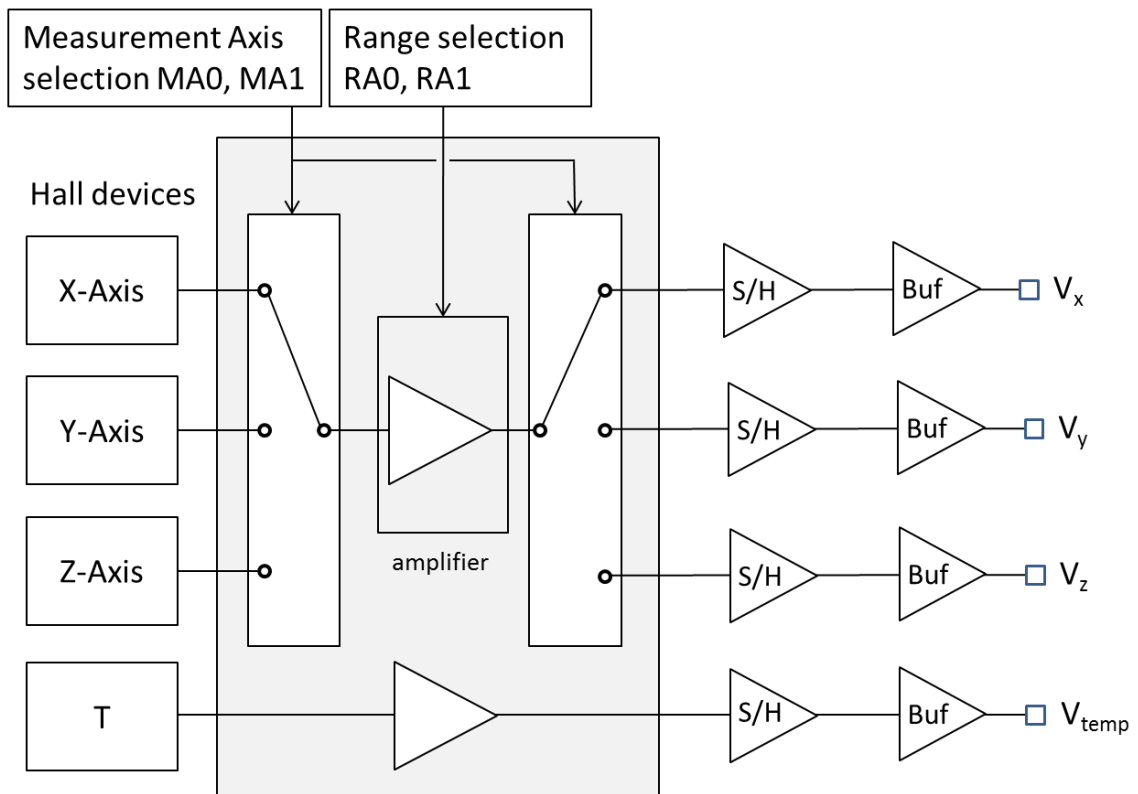

Figure 4. Block diagram of the signal conditioning – analog mode

4-3 OUTPUT STAGE

The analog voltages representing the magnetic field and the chip temperature are buffered through the output “Buf” stage. The maximum drive capability of the analog outputs is 100 k Ω / 500 pF.

The magnetic field outputs (V_x , V_y and V_z) are referenced to $V_{CC}/2$, corresponding to zero magnetic field. This reference voltage is generated internally and available on the REF pin.

V_{temp} is referenced to GND.

4-4 APPLICATION CIRCUIT

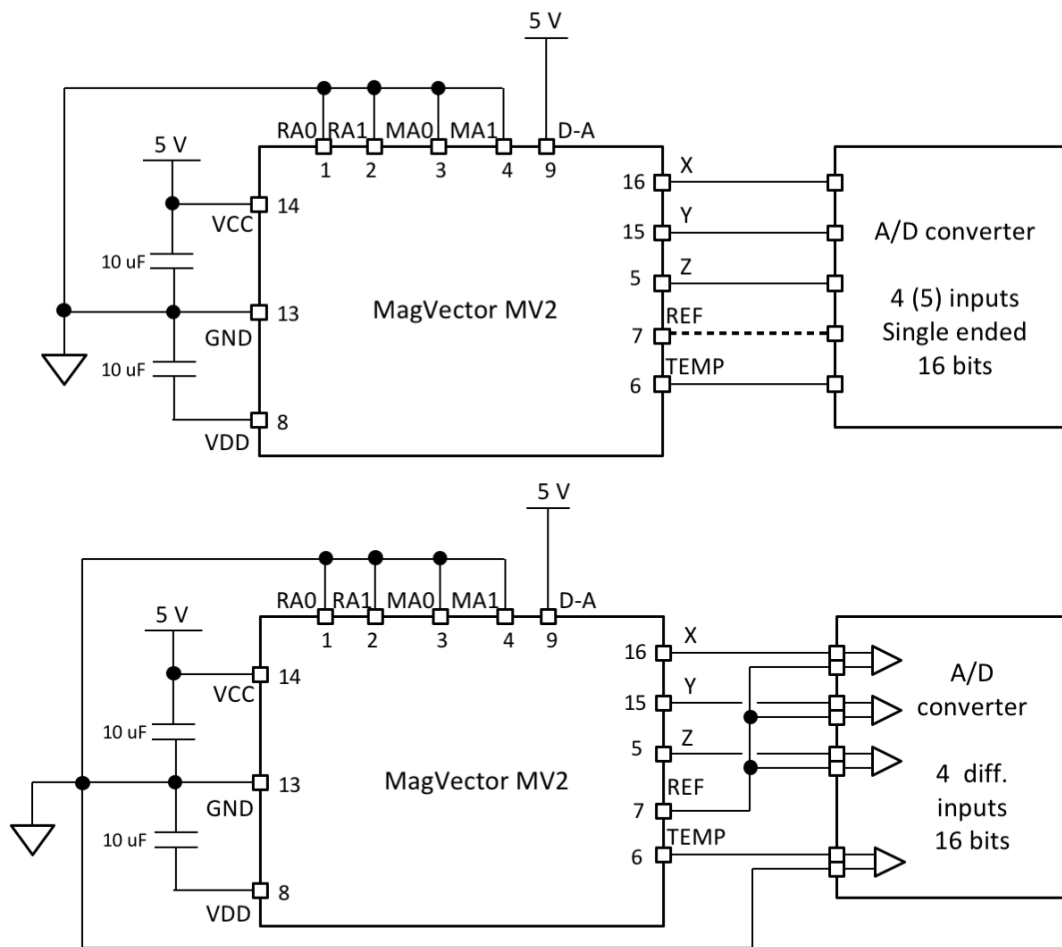

Figure 5. Circuits for sensor control and reading – analog mode

Note that all input pins are in pull-down configuration, i.e. if an input pin is not connected (left floating), it is considered as a LOGIC 0 setting.

4-5 OPTION SETTINGS IN ANALOG MODE

Note that the D-A pin has to be tied to LOGIC 1 (VCC). The following options can be selected in analog mode:

Table 7. Selectable options – analog mode

Pin	Name	Description	See
1	RA0	Range LSB	Page 11, Section 4-6
2	RA1	Range MSB	Page 11, Section 4-6
3	MA0	Measurement Axis LSB	Page 11, Section 4-7
4	MA1	Measurement Axis MSB	Page 11, Section 4-7
10	LP	Low Power	Page 11, Section 4-8
11	INV	Invert	Page 12, Section 4-9
12	EMR	Extended Measurement Range	Page 12, Section 4-10

4-6 RA – RANGE

Pins: RA0 (1), RA1 (2)

The RA parameter sets the amplification gain. When the measured magnetic field is within the range (between - range to + range), the sensor output is proportional to the applied magnetic field amplitude.

Table 8. Range selection – analog mode

RA1	RA0	Magnetic field range
0	0	±100 mT
0	1	±300 mT
1	0	±1 T
1	1	±3 T

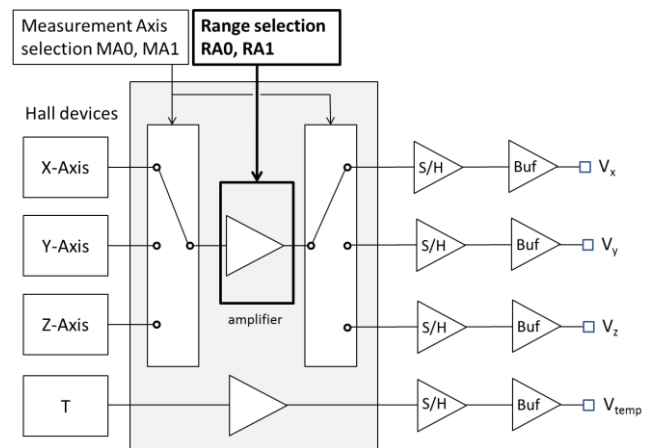

4-7 MA – MEASUREMENT AXIS

Pins: MA0 (3), MA1 (4)

The parameter MA determines which Hall device is amplified. Depending on the setting, all 3 axes are sequentially scanned and amplified, or the scanning is stopped and only one selected axis is amplified. See the table below.

The pins MA0 and MA1 are tied to GND (or left floating) or VCC to determine their logic state, LOGIC 0 or LOGIC 1, respectively.

Table 9. Measurement axis selection – analog mode

MA1	MA0	Measurement axis
0	0	3 axis
0	1	X axis
1	0	Y axis
1	1	Z axis

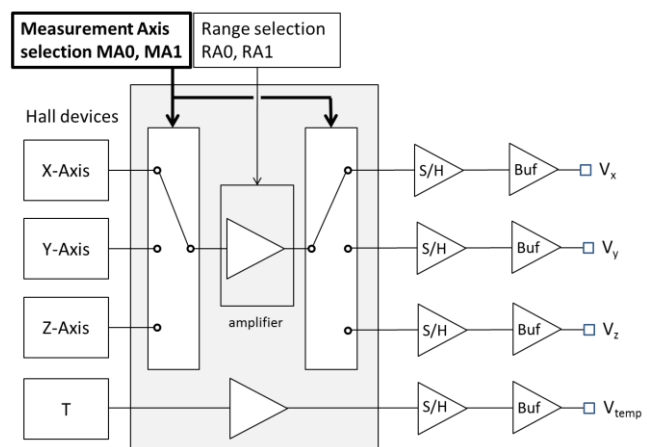

4-8 LP – LOW POWER

Pin: LP (10)

The MagVector MV2 can be switched to a low power mode by setting the LP pin to LOGIC 1. This mode reduces the current consumption by ~6 mA and the SNR

by a factor of $\sqrt{2}$. Note that other parameters, such as temperature drift or offset, can also change.

4-9 INV – INVERT

Pin: INV (11)

When the INV pin is tied to LOGIC 1, the MagVector MV2 reverses the Hall bias currents, and therefore reverses the measured magnetic field voltages relative to the REF pin (VCC/2). Toggling this option can be used, for example, to emulate a low frequency modulator / demodulator.

4-10 EMR – EXTENDED MEASUREMENT RANGE

Pin: EMR (12)

When the EMR option is enabled by tying the EMR pin to LOGIC 1, the MagVector MV2 increases the selected range by 30%. The intended purpose of this option is to approximately compensate the reduced voltage swing of the output buffer when using a 3.3 V supply instead of 5 V.

MagVector™ MV2 3-axis magnetic sensor

5-Digital Mode Operation

5-1 SPECIFICATIONS

Table 10. Performance specifications in digital mode.

Performance specifications in digital mode, VDD = 5 V, T = 25°C						
Parameter		Min	Typ	Max	Unit	Note
Sensitivity ²	3 T range		9.1		LSB/mT	
	1 T range		27.3			
	300 mT range		91			
	100 mT range		273			
Sensitivity drift	All ranges	-	±200	±400	ppm/°C	Can be compensated by programming
Measurement rate		0.375		3	kHz	Programmable
Number of bits delivered		14		16		Programmable
Spectral noise density	X & Y axis		330		nT/√Hz	
	Z axis		225		nT/√Hz	
RMS noise	X & Y axis		8		μT	RMS (0 - 600 Hz)
	Z axis		5.5		μT	RMS (0 - 600 Hz)
Static offset ²			250	350	LSB	
Offset temperature drift			6		μT/°C	
Temperature output sensitivity ²			46		LSB/°C	
Temperature output @ 27°C			23000		LSB	

² Design targets; measured typical, minimum and maximum values are TBD.

Table 11. Serial Peripheral Interface specification

Maximum clock frequency	10 MHz
Clock duty cycle	50%
SPI standard: - CPOL (Clock Polarity) - CPHA (Clock Phase)	Mode 0: 0: CLK idle state = Low 0: CLK readout edge = Rising
CS idle state	High
CS setup time	50 ns
CS hold time	50 ns
DORD (Data order)	0: MSB first
Data word size	16 bits
Minimum data word separation	100 ns
Data availability	DR or MISO – see Section 5-16

5-2 SIGNAL CONDITIONING – DIGITAL MODE

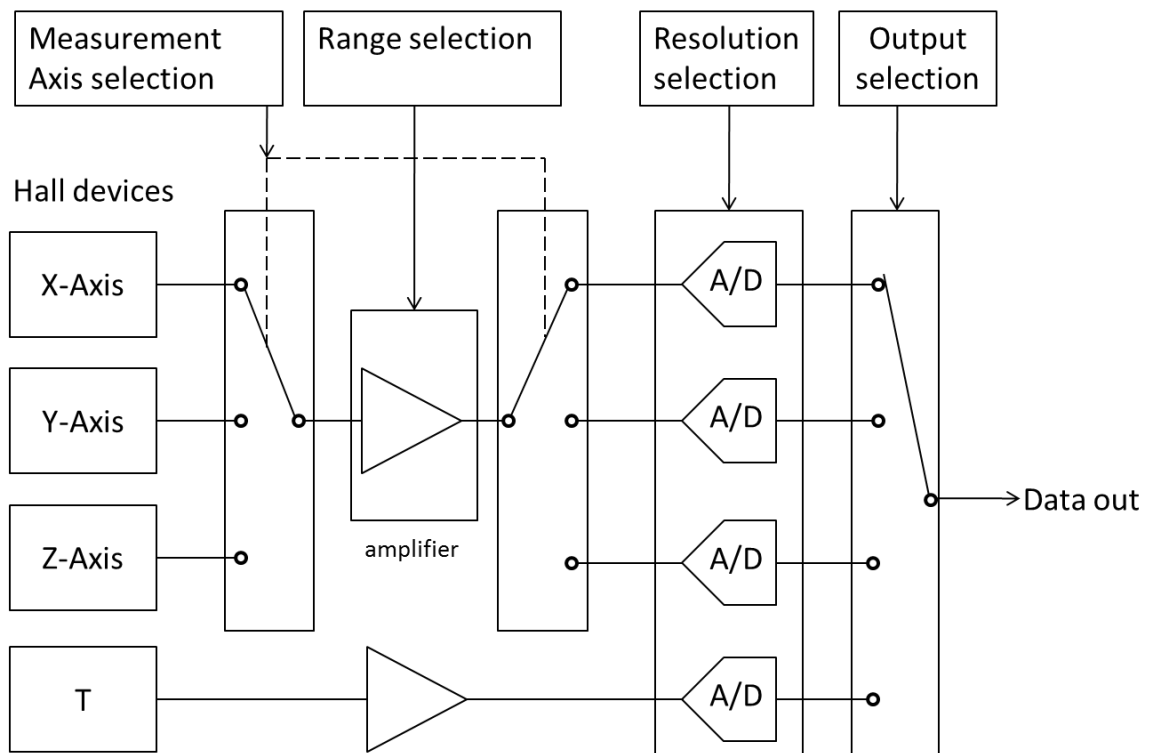

Figure 6. Block diagram of the signal conditioning – digital mode

5-3 A/D CONVERSION

The magnetic field signals out of the amplifier are de-multiplexed to the 3 A/D converters (see Figure 6).

The A/D output rate can be adjusted by the user, from 0.375 to 3 kHz. The output rate determines the integration time, and consequently the measurement resolution. Therefore, the parameter affecting the A/D rate is called “resolution” (RE). The user can trade off bandwidth against noise, choosing either low bandwidth with low noise, or high bandwidth with more noise.

The number of bits delivered by the MagVector MV2 always exceeds the resolution. In other words, the least significant bit is always fluctuating. This allows the user to further average the signal. When the resolution parameter is changed, the number of bits delivered to the output automatically changes (it can go from 14 to 16 bits).

When selecting the RE parameter, the user affects all four A/D conversions equally.

The A/D conversion block can be controlled by a logic input on INIT pin. Enabling INIT (tied to LOGIC 1) will reset and halt the A/D conversion; disabling INIT (floating or tied to LOGIC 0) will reinitialize and start the A/D conversion block operating. This option can be used to control the precise A/D conversion time. In normal operation, it is recommended to leave the INIT pin not connected.

The end of the A/D conversion is indicated by a Data Ready signal (see Section 5-5), which by default is routed to the DR pin. Optionally, this signal can be multiplexed with the MISO signal (see Section 5-16).

Note that enabling INIT generates a Data Ready, which should be cleared to avoid confusion with a “real” Data Ready once the A/D conversion has been restarted. To do so, it suffices to toggle the Chip Select.

5-4 OUTPUT STAGE

The digital value out of each A/D is stored in the output stage. When the user requests a certain output (one of the 3 axes or the temperature), the output stage multiplexer picks the selected channel and the value is transferred to the SPI interface.

Note that in the single axis mode, of the 3 magnetic field channels, only one contains meaningful data. For instance, if the measurement axis selected is only x, the channels y and z are disabled, and therefore provide zero-field digital values.

5-5 APPLICATION CIRCUIT

The MagVector MV2 is logical slave, and therefore the controller must send a chip select (CS) and clock signal (CLK) in order to receive the data from the sensor (MISO). The data consists of the digital value of the selected output. Prior to receiving the data, the user must send a request containing some user settings. The request usually contains the output channel.

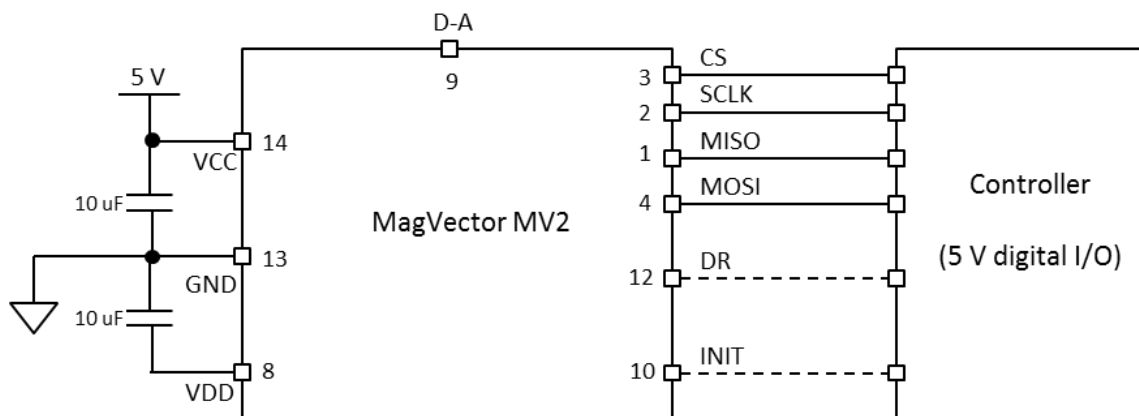

Figure 7. Circuit for sensor control and reading – digital mode

The Data Ready (DR) signal indicates that new data for all selected axes (see Section 5-15 MA – Measurement Axis) is ready (LOGIC 1); otherwise old data will be reread (LOGIC 0). DR passes from LOGIC 1 to LOGIC 0 as soon as the SPI transfer starts (CS goes from LOGIC 1 to LOGIC 0).

By selecting the appropriate option bit, the Data Ready signal can be multiplexed with MISO, instead of requiring a signal line of its own (see Section 5-16). The controller can also control the exact timing of the A/D conversion, using the INIT pin (see Section 5-3).

5-6 MULTIPLE DEVICES

It is possible to connect several MagVector MV2s on the same SPI bus. In this case, SCLK, MISO and MOSI are connected in parallel, while the CS signal is individual per chip. To avoid conflicting flows of data, only one data out (MISO pin) should be enabled at the time. For this reason the default value of the MISO pin is DISABLED and remains in a high impedance state (“tristate” logic) when the chip is in an idle state (CS high).

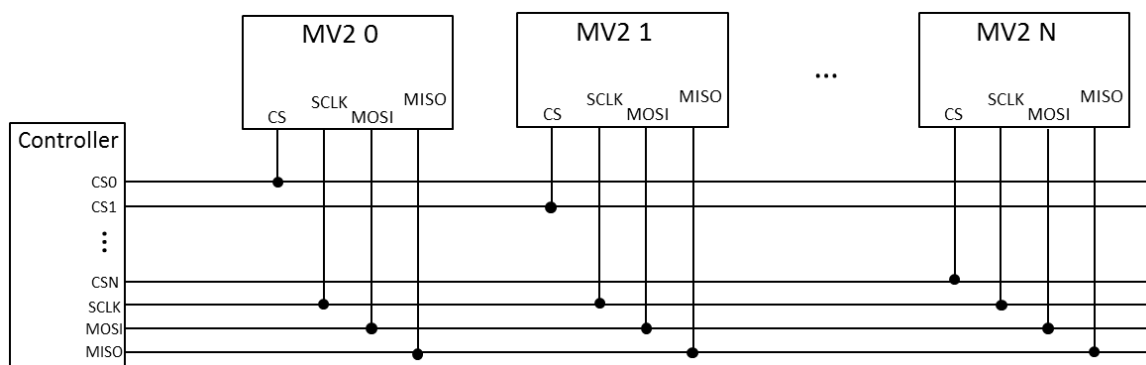

Figure 8. Parallel connection of MagVector MV2s

5-7 SERIAL COMMUNICATION

The MagVector MV2 is read and programmed by a master controller through a standard 4-wire Serial Peripheral Interface (SPI). See Table 11 for a summary of the SPI specification.

The sensor data are sent to the master via the MISO (Master In Slave Out) pin and the sensor can be programmed through MOSI (Master Out Slave In) pin. The MISO and MOSI words are 16 bits long. Within one single series of 16 clock counts, sent by the master, one MISO word and one MOSI word can be transmitted simultaneously. Two successive words must be separated by at least 100 ns.

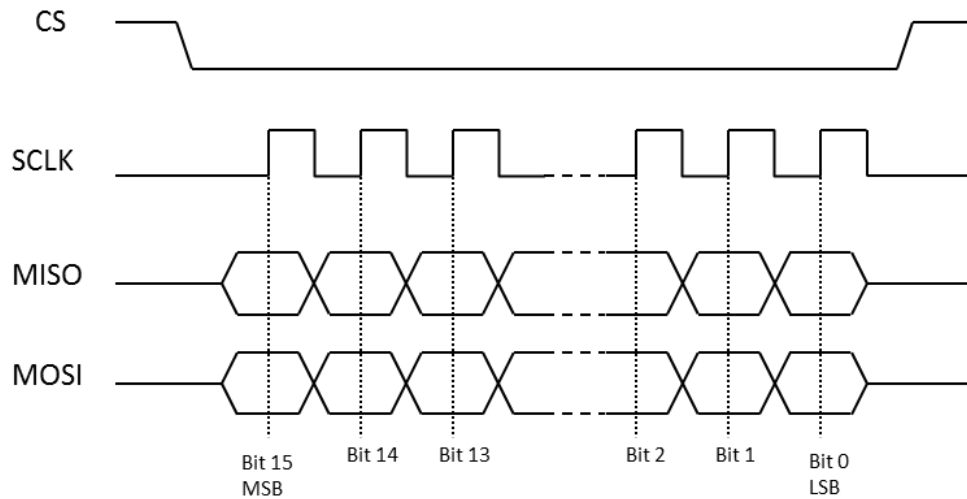

Figure 9. Timing diagram of one word

The availability of new data at the SPI port is indicated by DR signal. When a SPI communication cycle starts (falling edge of CS), the DR signal is cleared until new data is available in the SPI output buffer. The SPI output buffer refresh rate depends on the A/D output rate (see Section 5-3).

5-8 COMMUNICATION PROTOCOL

The sensor is configured by sending a 16-bit word through the MOSI pin (see Section 5-9). In particular, this includes the requested measurement axis. The configuration data are then stored in one of three volatile registers, and will remain until another data word is sent to the same register or until the chip is powered off.

The sensor returns the Hall measurement of the requested axis as a 16-bit unsigned integer value (see Section 5-10). As a data word is read from the MagVector MV2, the configuration data for the next data word to be read (indicating, for instance, another measurement axis) can be sent simultaneously, within the same series of 16 clock counts (see fig. 4).

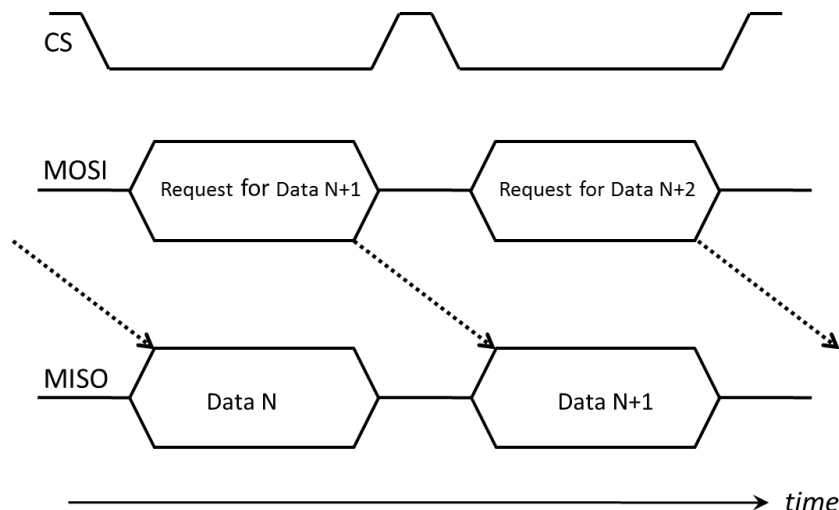

Figure 10. Sequence of data for communicating with the MagVector MV2

The user can read back the contents of the configuration registers at any time. By sending a request in the form of 8 bits (see Section 5-9), the MagVector MV2 returns the register value within the same transmission.

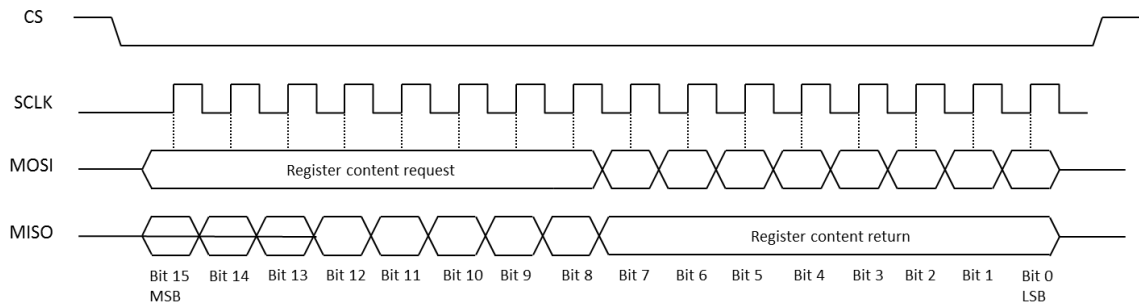

Figure 11. Timing diagram of the register read back

5-9 DATA FORMAT – DATA IN

To configure the device, a 16-bit word has to be sent. This word is composed of an 8-bit control address and an 8-bit value containing the user settings, as shown in Figure 12 and described in greater detail in Table 12.

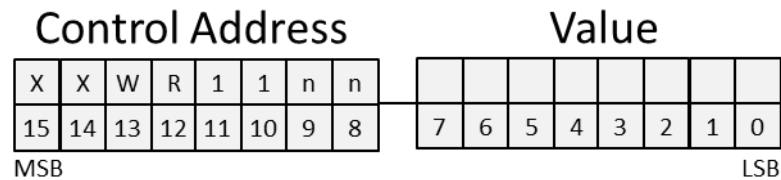
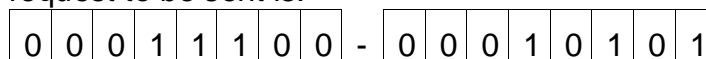

Figure 12. Format of Data In

Table 12. Format of Data In

Bit	Description
15 (MSB), 14	Don't Care
13	1 = Write: write the register
12	1 = Read: read back the register
11, 10	11
9, 8	Register number (see Section 5-11): 00: primary measurement specifications 01: other measurement options 10: temperature compensation and test
7 – 0 (LSB)	Register value to be programmed

Example: Configure the MagVector MV2 to read the Y-axis with a resolution of 15 bits, while the 3 measurement axes are scanned, with measurement range of 300 mT. The request to be sent is:



5-10 DATA FORMAT – DATA OUT

The magnetic field amplitude is transmitted in a word of 16 bits. The MSB is transmitted first.

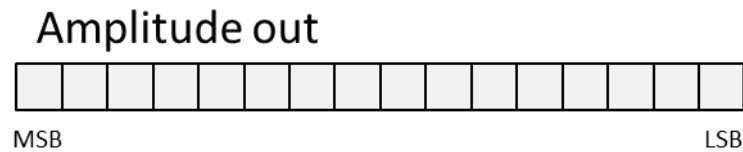

Figure 13. Format of Data Out

The digital output is an unsigned integer value, comprised between 0 and 2^N , where N is the selected resolution of the A/D converter (N=13, 14, 15 or 16; see Section 5-12).

At zero magnetic field, the output would ideally be half the maximum value, $2^N/2$ (see Figure 14 for the case N =16 and 100 mT field range). In reality, the value will correspond to the sensor offset. When the MagVector MV2 is exposed to a magnetic field, the output value is proportional to the field up to the field range (100 mT, 300 mT, 1 T or 3 T), with a proportionality constant being the sensitivity parameter in Table 10. The ADC saturates at a field about 20% larger than the range.

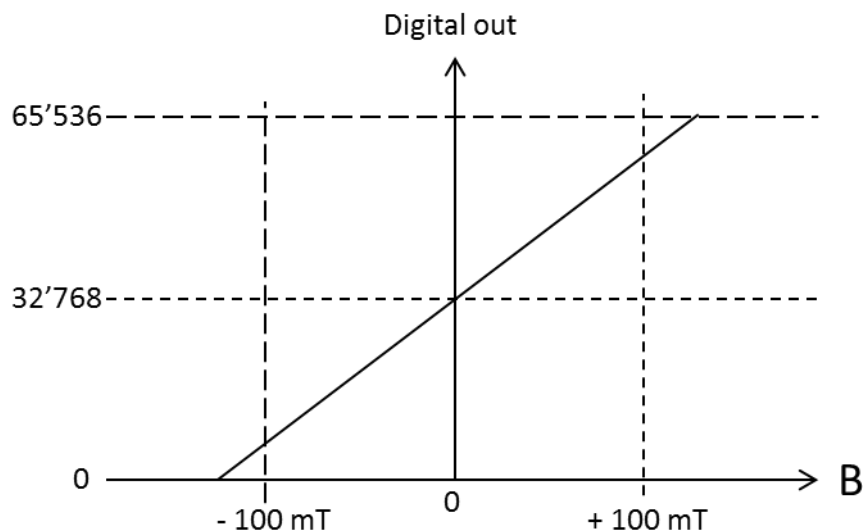

Figure 14. Output of one particular axis as a function of the field amplitude when the resolution is 16 bits, unsigned value representation.

5-11 REGISTERS

The following tables summarize the function of each bit in the three registers. Subsequent sections provide additional detail.

Table 13. Contents of Register 00

Register 00		Default value: all zeroes	
Bit	Name	Description	See
7 (MSB)	MA1	Measurement Axis MSB	Page 22, Section 5-15
6	MA0	Measurement Axis LSB	Page 22, Section 5-15
5	RE1	Resolution MSB	Page 22, Section 5-14
4	RE0	Resolution LSB	Page 22, Section 5-14
3	RA1	Range MSB	Page 21, Section 5-13
2	RA0	Range LSB	Page 21, Section 5-13
1	OS1	Output Selection MSB	Page 21, Section 5-12
0 (LSB)	OS0	Output Selection LSB	Page 21, Section 5-12

Table 14. Contents of Register 01

Register 01		Default value: all zeroes	
Bit	Name	Description	See
7 (MSB)	LMR	Large Measurement Range	Page 25, Section 5-22
6	SC	Spinning Current	Must be zero
5	EMR	Extended Measurement Range	Page 24, Section 5-21
4	HC	High Clock	Page 24, Section 5-20
3	INV	Invert	Page 24, Section 5-19
2	LP	Low Power	Page 24, Section 5-18
1	PO	Permanent Output	Page 24, Section 5-17
0 (LSB)	SP	Status Position	Page 23, Section 5-16

Table 15. Contents of Register 10

Register 10		Default values: DSB = TSC = 0, TC = 0001	
Bit	Name	Description	See
7 (MSB)	DSB	Disable Separated Bias	Must be zero
6	TC3	Temperature Compensation 3 (MSB)	Page 25, Section 5-23
5	TC2	Temperature Compensation 2	Page 25, Section 5-23
4	TC1	Temperature Compensation 1	Page 25, Section 5-23
3	TC0	Temperature Compensation 0 (LSB)	Page 25, Section 5-23
2	TSC	Test System Clock	Must be zero
1		Unused	
0 (LSB)		Unused	

5-12 OS – OUTPUT SELECTION

Register: 00

Bits: <Bit0> and <Bit1>

This option selects the channel (Bx, By, Bz or T) that will be delivered in the next SPI word out.

Note: when changing the range, or when changing the axis in single axis mode, the user should wait until the value is stable. The required delay corresponds to the ADC refresh rate: from 0.375 kHz to 3 kHz, depending on the resolution chosen.

Table 16. Output Selection

OS ₁	OS ₀	Data Out
0	0	Bx
0	1	By
1	0	Bz
1	1	T

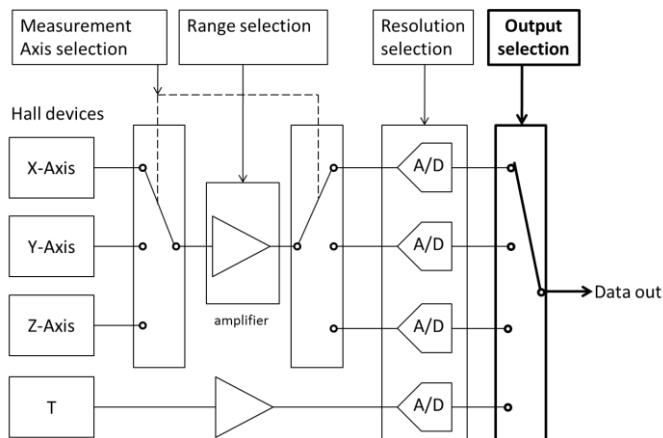

5-13 RA – RANGE

Register: 00

Bits: <Bit2> and <Bit3>

The RA parameter sets the amplification gain. When the measured magnetic field is within the range (between - range to + range), the sensor output is proportional to the applied magnetic field amplitude.

Note that the range also depends on the Extended Measurement Range (EMR – see Section 5-21) and Large Measurement Range (LMR – see Section 5-22) bits; the effective range is $RA * (1 + 0.333 * EMR + 9 * LMR)$.

Table 17. RA – Range selection – digital mode

RA ₁	RA ₀	Magnetic field range
0	0	±100 mT
0	1	±300 mT
1	0	±1 T
1	1	±3 T

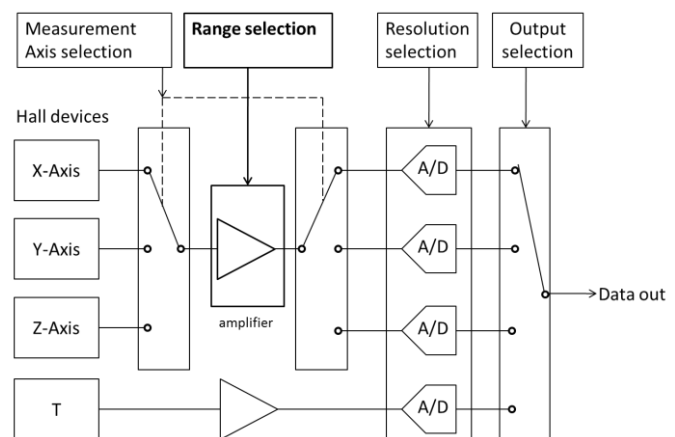

5-14 RE – RESOLUTION

Register: 00

Bits: <Bit4> and <Bit5>

The resolution of the Analog-to-Digital (A/D) conversion is set by the parameter RE. This parameter affects the conversion time and the refresh rate at the output. Since a greater integration time reduces the noise, the parameter RE also changes the number of delivered bits.

Table 18. RE – Resolution Selection

RE ₁	RE ₀	Number of bits	Refresh rate (kHz) ³
0	0	14	3
0	1	15	1.5
1	0	16	0.75
1	1	16	0.375

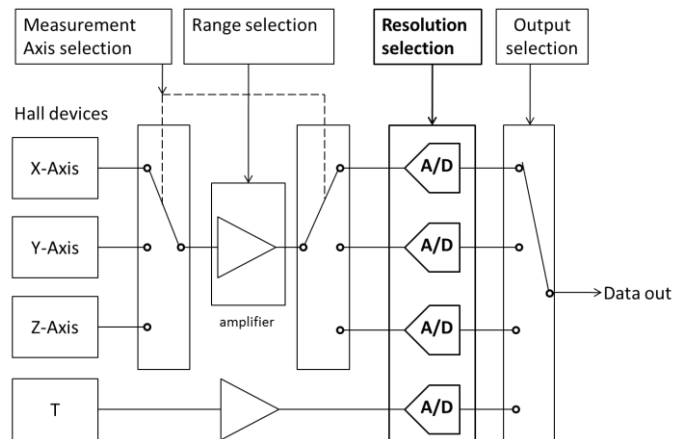

When the number of bits delivered N is smaller than 16, then the last 16-N bits (LSB) are zeros. For instance, if the number of bits delivered is 14, the output format is as follows:

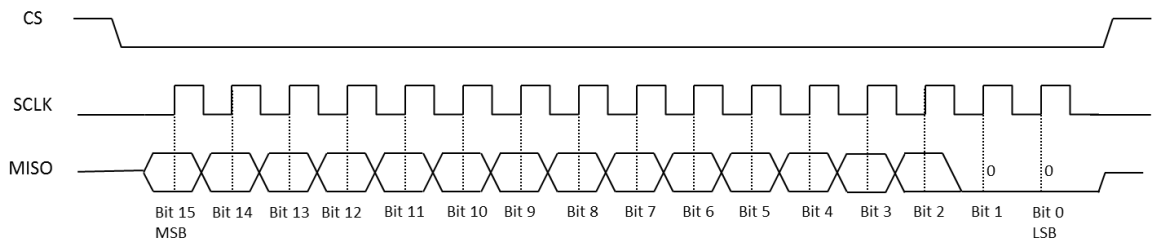

Figure 15. Timing of the data out when the resolution set to 14 bits.

5-15 MA – MEASUREMENT AXIS

Register: 00

Bits: <Bit6> and <Bit7>

The parameter MA determines which Hall device is amplified. Depending on the setting, all 3 axes are sequentially scanned (at the rate specified by the RE parameter – see Section 5-14) and amplified, or the scanning is stopped and only one selected axis is amplified. See the table below.

³ Indicates maximum acquisition rate for all selected axes (see Section 5-15 MA – Measurement Axis) and temperature.

Note:

By eliminating switching noise, the single-axis modes provide improved resolution.⁴

Table 19. MA – Measurement axis selection – digital mode

MA ₁	MA ₀	Measurement axis
0	0	3 axes
0	1	X axis
1	0	Y axis
1	1	Z axis

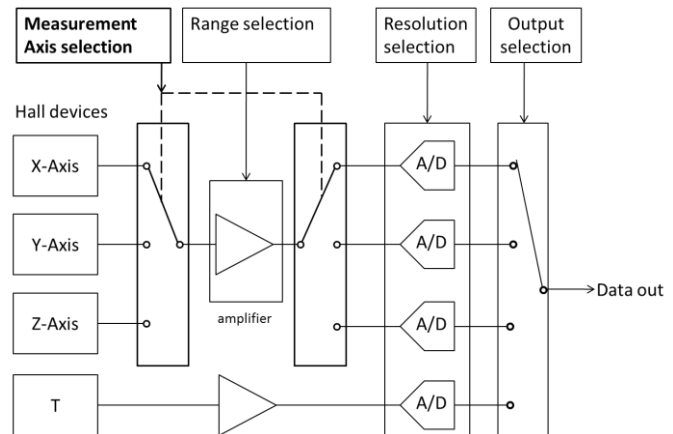

5-16 SP – STATUS POSITION

Register: 01

Bits: <Bit0>

The availability of a new data to be read via SPI is indicated by the status signal Data Ready (see Section 5-5). By default, this signal is routed to the DR pin. To minimize the number of connections between the MagVector MV2 and a controller, the DR signal can be multiplexed with the MISO pin when SPI is idle (CS pin at LOGIC 1).

Note that the PO (Permanent Output MISO) option has to be enabled to use this option.

The hardware position of Data Ready signal is summarized below.

Table 20. Status Position bit

SP	CS	Pin 1	Pin 12
0	0	MISO	DR
0	1	MISO	DR
1	0	MISO	hiZ
1	1	DR	hiZ

⁴ However, switching between single-axis modes (e.g. acquiring successive blocks of data with MA = 01, 10, 11, 01, 10, 11, ...), has been observed to cause small jump-discontinuities on each of the axes. The cause for this behavior is TBD.

5-17 PO – PERMANENT OUTPUT

Register: 01

Bits: <Bit1>

By default, the SPI output is disabled and the MISO pin is in a high impedance state (tri-stated) when the SPI is in idle state (CS pin is tied to LOGIC 1). This allows connecting several MagVector MV2s in parallel on the same SPI bus.

However, a MISO pin in high impedance state may generate a significant current consumption out of the master device. Therefore, if there is only a single MagVector MV2 on the SPI bus, it is recommended to permanently activate the MISO output. In this case, the MISO output remains at a well-defined logic level, even when SPI is idle (CS pin at LOGIC 1).

5-18 LP – LOW POWER

Register: 01

Bits: <Bit2>

The MagVector MV2 can be switched to a low power mode. This mode reduces the current consumption by ~6 mA and the SNR by a factor of $\sqrt{2}$. Note that other parameters, such as temperature drift or offset, can also change.

5-19 INV – INVERT

Register: 01

Bits: <Bit3>

When the INV option is enabled, the MagVector MV2 reverses the Hall bias currents, and therefore reverses the measured magnetic field outputs relative to $2^N/2$ (where N represents the ADC resolution). Toggling this option can be used, for example, to emulate a low frequency modulator / demodulator.

5-20 HC – HIGH CLOCK

Register: 01

Bits: <Bit4>

Enabling the HC option doubles the analog clock, which improves the SNR, typically by a factor of $\sqrt{2}$. However, in three-axis measurement mode (MA = 00), the MagVector MV2 may suffer from a slight cross-sensitivity between axes, and selecting this option will provide worse cross sensitivity.

5-21 EMR – EXTENDED MEASUREMENT RANGE

Register: 01

Bits: <Bit5>

Enabling the EMR option increases the selected range (RA – see Section 5-13) by 30%. In principle, this option is intended to be used in analog mode (see Section 4-10), to approximately compensate the reduced voltage swing of the output buffer when using a 3.3 V supply instead of 5 V.

5-22 LMR – LARGE MEASUREMENT RANGE

Register: 01

Bits: <Bit7>

Enabling the LMR option increases the selected range (RA – see Section 5-13) by 10x. This option is intended to extend the measurement range to 10 or 30 T, for very strong fields.

5-23 TC – TEMPERATURE COMPENSATION

Register: 10

Bits: <Bit3> through <Bit6>

Typically, the sensitivity of the Hall devices drifts with temperature (see Table 10). In order to compensate the temperature induced sensitivity drift, the Hall bias can be programmed to acquire a linear dependence with temperature. By default, TC=0001, which means that the gain is constant. The optimum value of TC needs to be found experimentally.

MagVector™ MV2 3-axis magnetic sensor

6-Evaluation Kit

The MagVector™ MV2 Evaluation Kit provides a flexible turnkey hardware and software environment that allows all features of the MagVector MV2 to be exercised. The kit consists of:

- Test board with MagVector MV2 sensor
- Preprogrammed Arduino board that connects to the test board
- Arduino firmware to drive the MagVector MV2, including source code
- Host software to exercise the MagVector MV2, including source code
- Two unmounted MagVector MV2 sensors

6-1 TEST BOARD

The test board is as shown in Figure 16. The schematics are shown in Figure 17, and the signal routing is summarized in Table 21.

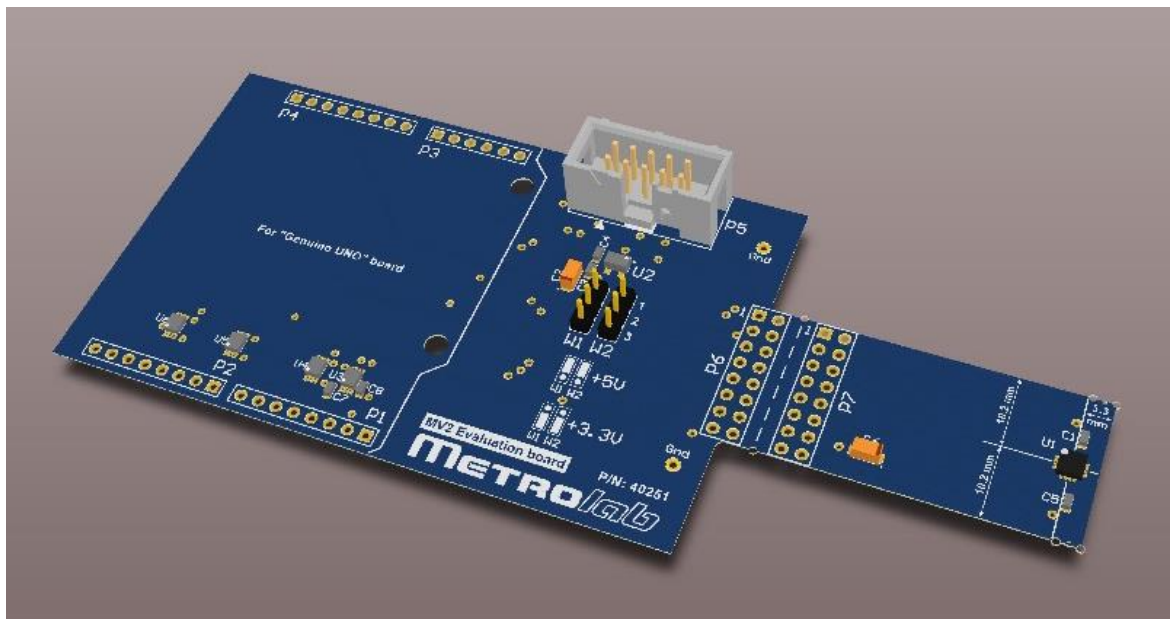

Figure 16. MagVector MV2 Evaluation Kit test board.

The MagVector MV2 is located on the end of the protrusion shown on the right, at location U1. The exact location of its field sensitive volume is indicated on the PCB. The MV2's thermal flag is soldered to a thermal pad, which in turn is connected by thermal vias to the ground plane on the back side of the protrusion.⁵ If needed, the protrusion can be cut off, and reconnected to the rest of the test board with a ribbon cable (ribbon-cable connectors at P6 and P7).

The test board can power the MV2 at 3.3V or 5V, selectable by two jumpers at W1 and W2. The jumper settings are as indicated on the PCB. If 5V is selected, the MagVector MV2 is powered directly by the 5V supply provided by the Arduino,

⁵ See, for example, the [Cirrus Logic Application Note AN315](#), "Thermal Considerations for QFN Packaged Integrated Circuits."

and uses the internal regulator. If 3.3V is selected, the MagVector MV2 is powered by a precision regulator, powered in turn by the Arduino's 5V supply.

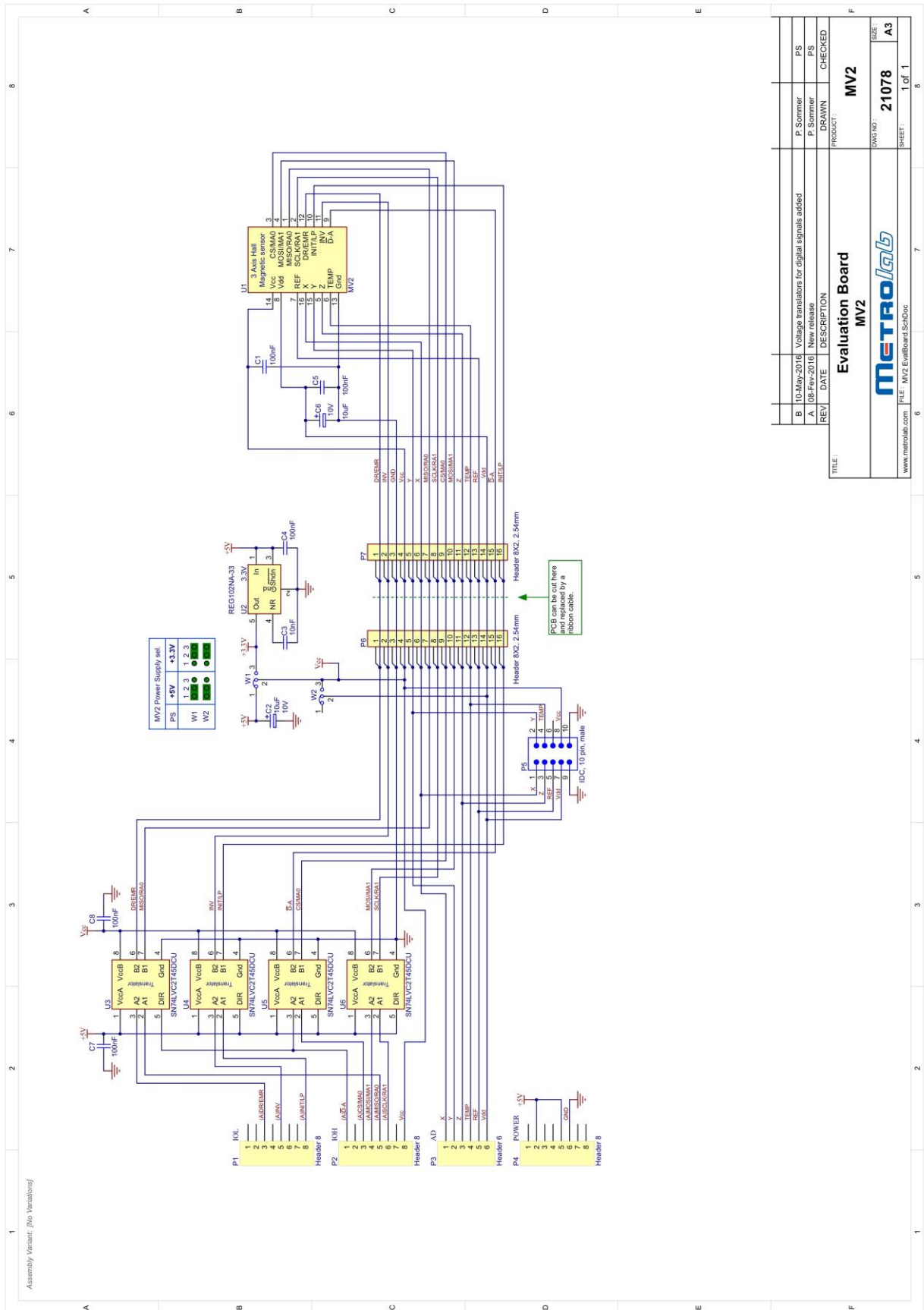

Figure 17. Schematics of MagVector MV2 Evaluation Kit test board

Table 21. Signal routing of MagVector MV2 Evaluation Kit test board

MagVector MV2			Arduino UNO			Description
Pin	Analog	Digital	Header pin	Signal	Direction	
1	RA0	MISO	IOH-5	MISO	Out / In	Range / SPI MISO
2	RA1	SCLK	IOH-6	SCK	Out	Range / SPI clock
3	MA0	CS	IOH-3	SS	Out	Axis select / Chip Select
4	MA1	MOSI	IOH-4	MOSI	Out	Axis select / SPI MOSI
5	Z	-	AD-3	AD2	In	Bz analog output
6	TEMP	-	AD-4	AD3	In	Temperature analog output
7	REF	-	AD-5	AD4	In	VCC/2 analog output
8	VDD (3.3V)		AD-6	AD5	In	Core supply monitor
9	D-A (0V or VCC)		IOH-1	IO8	Out	Digital-analog selection
10	LP	INIT	IOL-8	IO7	Out	Low power / Start ADC
11	INV	-	IOL-5	IO4	Out	Invert
12	EMR	DR	IOL-3	IO2	Out	Large range / Data Ready
13	GND		POWER-6	GND	-	Ground
14	VCC (5V or 3.3V)		IOH-8	AREF	In	VCC for ADC reference
15	Y	-	AD-2	AD1	In	By analog output
16	X	-	AD-1	AD0	In	Bx analog output
-	-	-	POWER-5	+5V	-	5V supply from Arduino

Note that all the analog-output signals – X, Y, Z, TEMP, plus REF and VCC – are routed to the Arduino UNO’s analog inputs, where they can be digitized. However, the Arduino UNO has 10-bit ADCs; to digitize the signal with higher resolution, an external digitizer can be connected to connector P5. The pin-out of this connector is shown in Table 22.

Table 22. Connections from MagVector MV2 Evaluation Kit test board to external digitizer.

Pin	Signal
P5-1	X
P5-2	Y
P5-3	Z
P5-4	TEMP
P5-5	REF
P5-6	n/c
P5-7	VDD
P5-8	VCC
P5-9	GND
P5-10	GND

6-2 ARDUINO BOARD

Arduino is a widely-used, open-source prototyping platform based on easy-to-use hardware and software. The Arduino Integrated Development Environment (IDE) and extensive documentation is available from the site <https://www.arduino.cc>.

An Arduino UNO, touted as the most robust board in the Arduino family, is included in the MagVector MV2 Evaluation Kit. Note that due to a trademark conflict, the Arduino UNO is sold as the “Genuino UNO” outside of the USA.

As shown in Figure 18, the Arduino UNO's connectors mate exactly with those on the test board: the Arduino UNO Digital headers (IOL and IOH) connect to P1 and P2, respectively, on the test board; the Arduino UNO Analog (AD) and Power (POWER) headers connect to P3 and P4, respectively, on the test board. Note that the last two pins of the Digital header (IOH-9 – SDA and IOH-10 – SCL) are not connected to the test board.

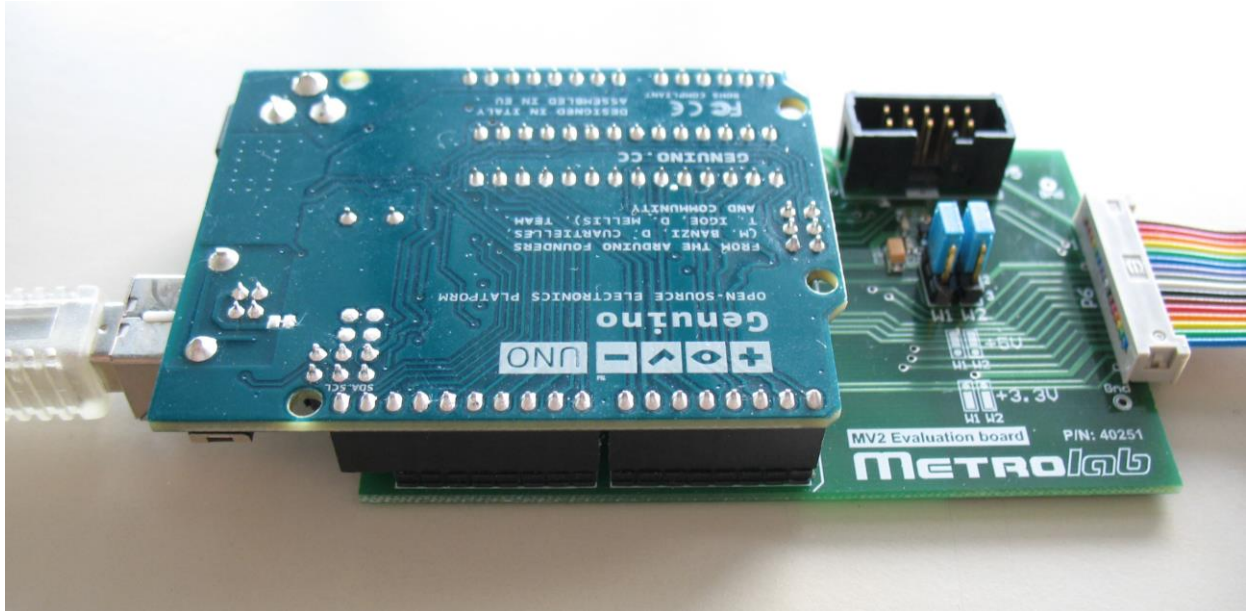

Figure 18. Arduino/Genuino UNO connected to MagVector MV2 test board.

The Arduino UNO is usually powered by USB, but it can optionally be powered by an external supply of 7 to 12V – see the technical documentation for the Arduino UNO.

The Arduino UNO connects to the host computer via a standard USB cable. It uses the USB CDC (USB Communications Device Class) protocol, which automatically creates a virtual serial port on modern Windows, Macintosh or Linux platforms. The serial port is named as follows:

- Windows: COMx, where “x” depends on the number of other COM ports installed. For the Arduino to be properly recognized, you have to install the “arduino.inf” file included in the directory “MV2\binaries\windows\drivers” of the MagVector MV2 Evaluation Kit: in the Windows Explorer, right-click on the file name and select “Install”.
- Macintosh: /dev/cu.usbmodemX, where “X” depends on the USB port the Arduino is plugged into.⁶ Use the command “ls /dev/cu.usbmodem*” to determine the exact name of the virtual serial device. USB CDC support is included in Mac OS X 10.3.7 and later.
- Linux: /dev/ttyACMx, where “x” depends on the number of other ACM (“Abstract Control Model”) modems installed.⁶ You may have to modify the access rights; see, for example, [this post for Ubuntu](#). Note that the

⁶ In fact, two devices are created: /dev/tty... and /dev/cu.... In Unix systems, /dev/tty was historically used for incoming calls on a modem; an open will stall until the modem asserts DCD (Data Carrier Detect). In contrast, /dev/cu was used for outgoing calls (“cu” stands for “calling unit”), and an open completes immediately. In this context, you should use /dev/cu.

standard rxtx library does not support these device names; you can use a patched version of the library (see, for example, [this patch for Ubuntu](#)), or you can create a symbolic link from /dev/ttyACMx to /dev/ttyUSBx. The Arduino IDE (see Section 6-3) uses a patched version of the rxtx library.

Note that the Arduino enumerates itself as an ACM modem, but in fact it does not respond to the Hayes control protocol at all.

6-3 ARDUINO FIRMWARE

6-3-1 Functional overview

The Arduino firmware is a general-purpose driver, capable of exercising every feature of the MV2, in either analog or digital mode.

It reads a command script from the host serial port, executes it, and returns the results via the host serial port. The command script may include a single level of looping. The command script input and the resulting output have a header specifying the transfer length and a trailer with a CRC. The output also includes a return status.

The script buffer sent to the firmware is structured as follows: (lengths given as 16-bit words)

Header (1 W)	Script (64 W max)	CRC (1 W)
--------------	-------------------	-----------

The response buffer received from the firmware is structured as follows:

Header (1 W)	Results (496 W max)	Status (2 W)	CRC (1 W)
--------------	---------------------	--------------	-----------

- In both cases, Header is the length in bytes of the entire buffer to be transferred (including header and CRC), and CRC is the 16-bit exclusive-OR of the entire buffer up to the CRC.
- Script is a variable-length list of 1-word commands, as defined in Subsection 6-3-2.
- Results is a variable-length list of 1-word values containing the return value for each command that returns one.
- Status is a 1-word Error Code followed by a 1-word Error Description, as defined in Subsection 6-3-3.

6-3-2 Command definitions

The general command structure is as follows:

Command Type								Command Value							
15 MSB	14	13	12	11	10	9	8	7	6	5	4	3	2	1	0 LSB

- Bits 15 and 14 define a class of commands:
 - 00: Digital commands
 - 01: Analog commands
 - 11: Miscellaneous commands
- Bits 13 to 8 define a specific command.
- Bits 7 to 0 define the value to write.

The commands are summarized in Table 23:

Table 23. Command definitions.

DIGITAL MODE COMMANDS			
Command Type (Hex)	Command Value	Description	Return value
1C	00	Read Register 00	Register 0 contents
1D	00	Read Register 01	Register 1 contents
1E	00	Read Register 10	Register 2 contents
2C	XX = Register value	Write Register 00	Previously selected data value
2D	XX = Register value	Write Register 01	Previously selected data value
2E	XX = Register value	Write Register 10	Previously selected data value
01	00 or 01	Set / Reset INIT bit	None
02	00	Wait for DR	None
ANALOG MODE COMMANDS			
Command Type (Hex)	Command Value	Description	Return value
41	00	Digitize B _x	B _x
42	00	Digitize B _y	B _y
43	00	Digitize B _z	B _z
44	00	Digitize Temperature	Temperature
45	XX: Bits 7 – 6 EMR 5 INV 4 LP 3,2 MA 1,0 RA	Set control lines	None
MISCELLANEOUS COMMANDS			
Command Type (Hex)	Command Value	Description	Return value
C1	00 or 01	Set digital/analog mode	None
C2	XX = loop count	Set loop start	None
C3	00	Set loop end	None
C4	00	Get firmware version	Firmware version, in Binary Coded Decimal (e.g. 0x0102 means version 1.2)

6-3-3 Return status definitions

Table 24. Return status definitions

Meaning	Error Code Field	Error Description Field
No Error	0	None
Syntax Error	101	Command number
Mode Error	102	Command number
Out of Memory Error	103	Command number
Nested Loop Error	104	Command number
Unspecified Loop Error	105	Command number
Bad CRC Error	201	None
Script Length Too Large Error	202	Script length
No Valid Data From Host Error	203	None
Transmission Error	204	None
ADC Time Out Error	301	Command number

6-3-4 Rebuilding the firmware

The Arduino UNO included with the MagVector MV2 Evaluation Kit is preprogrammed with the latest firmware. Unless you want to update or customize the firmware/software, you can ignore this subsection.

To recompile the firmware and reprogram the Arduino UNO, download and install the [Arduino Integrated Development Environment \(IDE\)](#), available for Windows, Macintosh and Linux. Once installed:

- Copy the firmware source code from the MagVector MV2 Evaluation Kit, in the directory “MV2/Source/instrument/MV2”, to a directory on your computer.
- Launch the Arduino IDE.
- Within the IDE, open the file MV2.ino.
- Select Tools > Board > Arduino/Genuino UNO.
- Select Tools > Port > (virtual serial port name, as described in Section 6-2).
- Select Sketch > Verify/Compile.
- Select Sketch > Upload.

Note that the Arduino IDE uses a default tab setting of 2 spaces, whereas the Metrolab code uses 4 spaces. To correct this, quit the Arduino IDE, open the Arduino preferences file, “preferences.txt”, change the “editor.tabs.size=” line, and restart the Arduino IDE. The preferences file is in AppData\Roaming\Arduino15 in Windows, ~/Library/Arduino15/ on Macintosh, and ~/.arduino15 in Linux.

6-4 HOST SOFTWARE

The host software uses the serial interface to the Arduino firmware to, for example, repeatedly measure B_x , B_y , B_z and Temperature.

6-4-1 Functional overview

The command scripts to be sent to the Arduino firmware (see Section 6-3-1) are read from a setup file, thereby allowing experimentation with all the MagVector MV2's options. The setup file is a human-readable XML (Extensible Markup Language) file.

The setup file contains two command scripts: one for initialization, and one for measurements. The measurement script also specifies:

- The expected location of the measurement results in the output array, along with a label.
- The number of times to run the measurement loop. If the count is zero, the measurement loop will run forever, until the user kills the program.
- Any loop commands, with its count and an option to average the results.

Included in the MagVector MV2 Evaluation Kit are two basic setup files, one for analog mode and one for digital mode.

The host software is written in C++, as a simple command-line program that can be compiled and run on Windows, Macintosh and Linux platforms. The results are written to the standard output, and errors to the standard error streams; this allows the results to be piped to another program or redirected to a recording file. The results can also be recorded to a file in the “Metrolab XML Record” (MXR) format.

6-4-2 Installation and execution

Copy the MV2 directory from the distribution medium to your computer. In a command shell, change your working directory to “MV2/binaries/<OS>”, where “<OS>” is your operating system type.

Then execute MV2Host, with the following syntax:

```
MV2Host <MV2ScriptXml-file> <MV2ScriptSchemaXsd-file> <COM port>  
[MXR-file]
```

where:

- <MV2ScriptXml-file> is the setup file that contains the commands sent to the MagVector MV2. The directory MV2/host/script contains two sample scripts, for analog and digital acquisition, respectively.
- <MV2ScriptSchemaXsd-file> is the XML schema file, used to check the syntax of the setup file. You should normally use the file MV2/host/script/MV2/host/script.xsd.
- <COM port> is the name (or, in UNIX-like systems, the path) of the virtual serial port where the Arduino is plugged in, as described in Section 6-2.
- [MXR-file] is an optional parameter that specifies the pathname of a “Metrolab XML Record” (MXR) file to which to record the measurements. This is a self-documenting, human-readable XML file. It consists of a header section and a body section; the body section, in turn, is decomposed into a series of datasets, each with a table of measurement data, column headings, and associated instrument settings.

Note that you may have to make the program executable (“chmod ugo+x MV2Host”). Also note that, for compatibility, MV2Host is built as a 32-bit executable.

6-4-3 Setup file format

Please see the sample files in the MV2/host/script directory.

The overall structure of a setup file is as follows:

```
<?xml version="1.0" encoding="UTF-8"?>
<scripts>
  <initialization>
    ...
  </initialization>
  <measurement repeat="...">
    ...
  </measurement>
</scripts>
```

where the <initialization> section defines the commands to be sent during initialization, and the <measurement> section during the measurement phase (see Section 6-4-1). The “repeat” parameter specifies the number of times the measurement script is to be executed; zero means an infinite number of times – i.e. until the user kills the program.

A command to be sent to the MagVector MV2 (see Table 23) is specified as follows:

```
<command outputIndex="..." outputName="...">
  <type>...</type>
  <value>...</value>
</command>
```

where the “<type>” section specifies the Command Type, and the “<value>” section the Command Value, as hexadecimal bytes, as shown in Table 23. The “outputIndex” parameter specifies the index in the output buffer (array of 16-bit words) where the return value will be located, and the “outputName” parameter specifies a name for this data. Since the output buffer is ignored during initialization, these two parameters can be dropped for commands in the <initialization> section.

A sequence of commands can be repeated using a <loop> section:

```
<loop count="..." average="true|false">
  ...
</loop>
```

where the “count” parameter specifies the loop count, and the “average” parameter specifies whether or not to average the results before returning them. Loops cannot be nested.

6-4-4 Recompilation

The MagVector MV2 Evaluation Kit host software is designed to be compiled in a Unix-style development environment (see Section 6-4-5). You must also have installed the libxml2 library and its headers (see Section 6-4-6).

Once these requirements have been met, the build process should be straightforward:

- Copy the MagVector MV2 Evaluation Kit software – the directory “MV2” – to your computer.
- In a command-line shell, change your working directory to MV2/host/build.
- Type “make”.

The Makefile has several options; the full syntax is as follows:

```
make [OPT=[DEBUG],[RELEASE]] [LIBXML_DIR=<path>] [all | clean]
```

where

- OPT=DEBUG compiles a debug version, with symbols and no optimization. Default is no symbols and -O3 optimization.
- OPT=RELEASE builds a 32-bit, statically-linked executable. Default is native architecture, dynamically linked.
- LIBXML_DIR=<path> specifies the location of libxml2 (see Section 6-4-6). Default is “../libxml”.
- The “all” target builds the application. This is the default target.
- The “clean” target deletes the build files.

6-4-5 Development environment

The build instructions are designed for a Unix-style development environment, using the Makefile mechanism. The recommended development environments for the different platforms are as follows:

Windows:

MinGW (Minimalist GNU for Windows) is a free and open source Unix-like development environment for creating native Windows applications. MSYS is an addition to MinGW, to provide a standard command shell. Install MinGW and MSYS as follows:

- Download the MinGW setup program from <http://www.mingw.org/>. Execute it, and click the Install button to launch the MinGW Installation Manager.⁷
- In the “MinGW Installation Manager,” select “Basic Setup” in the left-hand column, and mark the following packages for installation:
 - mingw32-base
 - mingw-developer-toolkit
 - mingw32-gcc-g++
 - msys-base
- Now select “All Packages” in the left-hand column, and mark the following additional packages for installation:
 - mingw32-liblzma
 - mingw32-pthreads-w32

⁷ See http://www.mingw.org/wiki/getting_started for more details.

- Install all packages by clicking on the menu Installation > Apply Changes.
- In the “msys\1.0\etc” subdirectory of your MinGW installation directory, there may be a file named “fstab”. If so, open it with a text editor; if not, create one. Add the line:
 - C:\MinGW /mingwsubstituting the full absolute path of your MinGW installation directory if different from C:\MinGW. Ensure that there is at least one blank line at the end of the file, then save and close the file. Ensure that the file name is “fstab,” without extension (text editors usually add “.txt” by default).
- Change your PATH environment variable:
 - Add the path to your MinGW bin directory, by default “c:\MinGW\bin”
 - Add the path to your MSYS bin directory, by default “c:\MinGW\msys\1.0\bin”

The MSYS launch script is located at “c:\MinGW\msys\1.0\msys.bat”. You have to manually create a shortcut if you want. Your MSYS home directory is “c:\MinGW\msys\1.0\home\<your user-name>”.

Macintosh:

- Install Apple’s Xcode development environment from the Mac App Store.
- In a command shell, execute “xcode-select --install” to install the command line tools.
- For older versions of MacOS, see [the Xcode installation instructions on the MacPorts web site](#).

Linux:

- Install the GNU C++ compiler. For example, in Ubuntu, execute “sudo apt-get install g++”, or install the “g++” package in the Ubuntu Software Center. To be able to compile a 32-bit application on a 64-bit system, be sure you have “multilib” support for gcc (e.g. “gcc-4.8-multilib” package under Ubuntu 14.04) as well as g++ (e.g. “g++-4.8-multilib”).

6-4-6 Installing the libxml2 library

Building the MagVector MV2 Evaluation Kit host software requires version 2.9.x or later of libxml2, a widely used XML (Extensible Markup Language) parser. The developer package, which includes the header files and both static- and dynamic-link libraries, are required. There are many ways to install libxml2 (see [xmlsoft.org](#)); here are a few possibilities:

Windows:

Download libxml2 and supporting libraries (iconv, zlib) from [the web site of Igor Zlatkovic](#), the maintainer of the Windows port. The three libraries are available [via FTP from his download area](#), as 7-Zip (“.7z”) archive files. Use, for example, the [Easy 7-Zip](#) utility to extract the subdirectories (bin, include, lib, share) to MV2/host/libxml, the default location expected by the Makefile. Include the MV2/host/libxml/bin subdirectory in the execution path, so the MV2Host.exe executable can find its DLLs. Note: because of incompatibilities between MinGW

and how this library was compiled, it cannot be statically linked with the MV2 host software; in this case, you can build libxml2 from scratch, as described below.

Macintosh:

Install [MacPorts](#) and use it to install version 2.9.x or later of the libxml2 package. To be able to build both 32- and 64-bit executables, also install the libxml2+universal variant.

Linux:

Install version 2.9.x or later of the libxml2-dev package. For example, in Ubuntu 14.04 or later, execute “sudo apt-get install libxml2-dev”, or do the equivalent in the Ubuntu Software Center. If you want to build a 32-bit application on a 64-bit machine, install the 32-bit development versions of this and its supporting packages (e.g. in Ubuntu, install “sudo apt-get install libxml2-dev:i386” and “...liblzma-dev:i386”). Earlier versions of Ubuntu may install an earlier version of libxml2; in this case, you can build libxml2 from scratch, as described below.

Build from scratch:

To build the libxml2 library from scratch:

- Download the libxml2 package from xmlsoft.org and extract it.
- Install the following tools, in addition to what was described in Section 6-4-5:
 - Windows: Download [the ZIP file containing pkgconfig for Windows](#) and extract it to your MinGW installation directory, by default “C:\MinGW”.
 - Macintosh: Using MacPorts, install the libtool, pkgconfig, autoconf, automake, and lzma packages.
 - Linux (e.g. Ubuntu): Install the autoconf, automake, autotools-dev, libtool, and python-dev packages.

- In a command shell, execute:

```
cd
tar -xzf libxml2-2.x.y.tar.gz
cd libxml2-2.x.y
libtoolize -force
("glibtoolize" for MacPorts)
aclocal
autoheader
autoconf
automake --add-missing

./configure --prefix=<MV2 root path>/MV2/host/libxml
(--with-lzma=... if lzma is not in the standard library directory).
make
sudo make install
```